

**FIST Metal Closure Organiser**

**Contents**

<b>1</b>	<b>Introduction</b>	<b>7</b>	<b>Installation of optical grounding wires (OPGW) with inner cable jacket and plastic loose tubes</b>
<b>2</b>	<b>General</b>		
	2.1 Abbreviations		7.1 Preparation
	2.2 Kit content		7.2 Installation
	2.3 Elements needed from the valise		
	2.4 Tools	<b>8</b>	<b>Closing cable clamps</b>
	2.5 Accessories	<b>9</b>	<b>Termination, sealing and routing of OPGW cable with <math>\leq 12</math> fibers/metal tube</b>
	2.6 Capacity	<b>10</b>	<b>Termination, sealing and routing of plastic sheeted FO cable or OPGW with inner cable jacket and plastic loose tubes with <math>\leq 12</math> fibers/plastic loose tube</b>
<b>3</b>	<b>Installation preparations</b>	<b>11</b>	<b>Termination, sealing and routing of OPGW cable with <math>\geq 12</math> fibers/metal tube</b>
<b>4</b>	<b>Preparation of the closure</b>	<b>12</b>	<b>Placing SOSA and/or SASA and routing fibers</b>
	4.1 Installation of cable feed through and metal plugs	<b>13</b>	<b>Closing the closure</b>
	4.2 Installation of cable clamps	<b>14</b>	<b>Mounting the closure without drilling holes</b>
<b>5</b>	<b>Installation of optical grounding wires (OPGW)</b>		
	5.1 Preparation		
	5.2 Installation		
<b>6</b>	<b>Installation of plastic sheeted FO cable</b>		
	6.1 Preparation		
	6.2 Installation		

**1 Introduction**

The Metal Closure Organiser is a single-ended design specially developed for use on the optical grounding wires (OPGW) of electrical power network lines. The closure is suitable for use above ground attached to high voltage towers, poles, walls or other support structures.

The base and dome are sealed with three screws and an O-ring system. Six round ports for single cable entry/exit are included in the base. The cables are attached with metal clamps and feed-through. The sealing is done by heat-shrinkable material. Two back-to-back pre-mounted FAS (Fiber arrangement System) plates each with a capacity of 38 tray units provide the foundation for mounting combinations of SOSA and/or SASA modules.

The FIST-MCO is the environmentally sealed enclosure for the fiber management system that provides the function of splicing and passive component integration in the external network. The product can be tailored to almost any required configuration by adding splicing and/or passive device sub-assemblies.

Follow all local safety regulations related to optical fibre plant elements.

**Dimensions**

Length	800 mm including mounting bracket
Diameter at base section	290 mm
Diameter of dome (internal)	212 mm

## 2 General

### 2.1 Abbreviations

- Fiber Arrangement System FAS
- Loose tube breakout system SECO
- Fiber break-out manifold to split bare fibers from a central core into groups of maximum 12 fibers PECO 1/12
- Fiber break-out manifold to split bare fibers from metal loose tubes into groups of maximum 12 fibers PECO 3/12

### 2.2 Kit content



- Metal dome
- Metal base (including the bracket for pole fixation)
- Assembly with pre-installed FAS plates
- O-ring
- Plugs to temporarily protect cable ports (6, pre-installed in base)
- Screws, nuts and washers
- Silica gel (to be replaced after each re-entry)
- 2 tray covers
- Tray wedge
- 2 feed-through and sealing kits
- 1 set cable clamps to hold 3 cables
- 4 plugs to seal off unused ports
- Installation instruction

### 2.3 Elements needed from the valise

Product Name	UOM	QTY/UOM	Product description	
FISTV-E7185-0510		1 rl	30 m	FOPT-CT: cable to FOPT-CS protection tube
FISTV-E7185-0509		1 rl	30 m	FOPT-CS: cable to SECO protection tube
FISTV-E7185-0511		1 rl	200 m	FOPT-SF: SECO to trays protection tube
FISTV-K341-2164-01		1 pck	100 pcs	SECO-1/4: single element break-out to 4 circuits
FISTV-T149-2347		1 pck	50 pcs	SECO-1/6: single element break-out to 6 circuits
FISTV-E7100-0010-S8127		1 pck	10 X10 g	Silica gel for inside the closure, to be replaced after each re-entry
FISTV-SPLI-COL		1 pck	30 sets	Split identification collets

### 2.4 Tools

Besides the standard tools necessary to install fiber optic closures, following tools are recommended.

- FACC-TUBE-CUTTER-01 to cut FOPT
- FACC-TUBE-STRIPPER-02 to strip non metallic loose tube
- FACC-HEAT-GUN-220V to shrink cable seals

## 2.5 Accessories

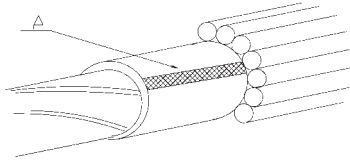

Product Name	QTY/UOM	Product description
MCO-GWSK-X	1 pc	Cable feed-through & seal kit for OPGW cable X: Depends on cable dimensions
MCO-OCSK-X	1 pc	Cable feed-through & seal kit for plastic sheathed FO cable X: Depends on cable dimensions
MCO-CAP-PG21	1 pc	Metal caps to plug unused ports
MCO-CLAMP-3-A	1 set	Cable clamps to hold 3 OPGW or FO cables between 10-14
MCO-CLAMP-3-B	1 set	Cable clamps to hold 3 OPGW or FO cables between 14.1-20
MCO-CLAMP-3-C	1 set	Cable clamps to hold 3 OPGW or FO cables between 20.1-26
MCO-DUCA-10	1 pc	Dummy rods to fill up not used entries in cable clamps
MCO-DUCA-12	1 pc	
MCO-DUCA-14	1 pc	
MCO-DUCA-16	1 pc	
MCO-DUCA-18	1 pc	
MCO-DUCA-20	1 pc	
MCO-DUCA-22	1 pc	
MCO-DUCA-24	1 pc	
MWTM-25/8-1000-239	1 m	
E7158-0439	1 m	Aluminium sheet to built-up OPGW cable between cable clamps
FIST-MCO-STRM-01-S8127	1 pc	Strength member fixation bracket
MCO-MOBRA-1	1 pc	Bracket to mount closure to pole with clamps (in case drilling holes in pole construction is not allowed)
FOSC-MCO-CABBLOCK	1 pc	To seal OPGW cable with metal inner jacket if inner jacket is not sealed at welded area (A on drawing)

## 2.6 Capacity

The base has two pre-installed FAS module base plates, each with a capacity of 38 tray units to accept splice modules.

Depending on the type of splice module involved, theoretical capacities are as follows

Single circuit splice module for splicing up to 2 fibers per tray	152 splices
Single element splice module for splicing up to 12 fibers per tray	384 splices
Passive optical components (e.g. splitters)	up to 2 X 32
Cable capacity	6 ports up to 25 mm diameter

	Cable feed through	Diameter (mm)	
	Ports	Min.	Max.
OPGW	1-6**	11	25
FO-cable	1-6**	9	22

\* The maximum capacity depends upon the type of cable used and must therefore be determined on a case-by-case basis

\*\* Are not numbered on base (see Drawing 4.1.4).

### 3 Installation preparations

3.1 Determine the position of the closure for attachment to high voltage towers, poles, walls or other support structures.

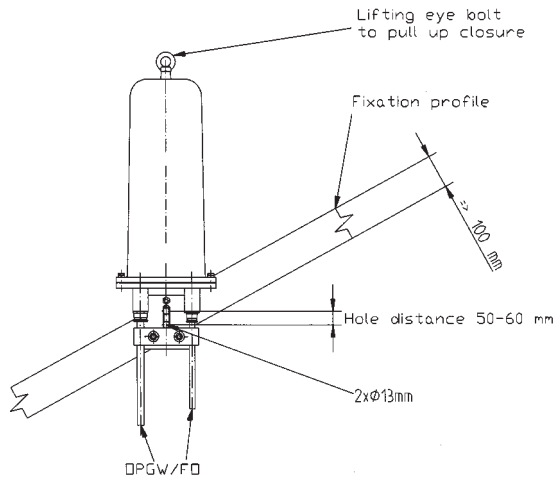

3.2 Drill the holes in the support structure according to drawing.  
**Note:** When it is not allowed to drill holes, use the MCO-MOBRA-1 kit to mount the closure (see point 14).

### 4 Preparation of the closure

#### 4.1 Installation of cable feed through and metal plugs

4.1.1 Untighten the screws and remove dome by turning it, remove O-ring.

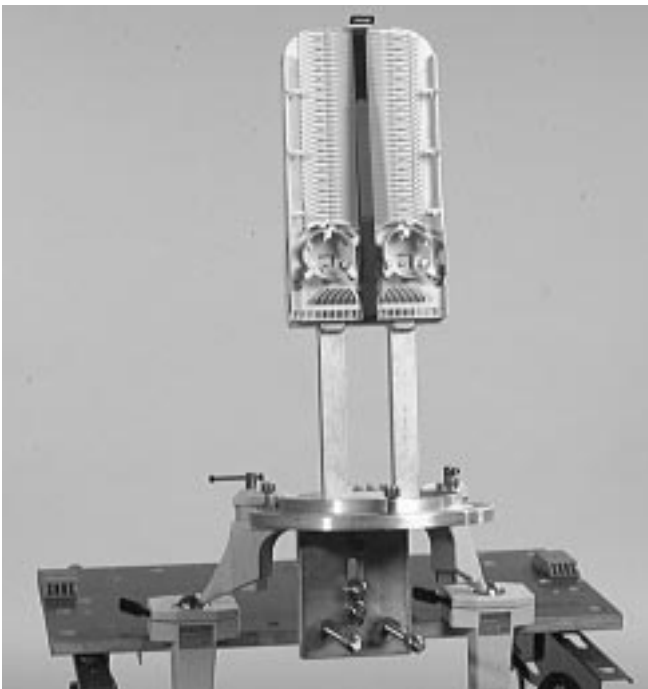

4.1.2 Position the closure on a mounting table.  
**Note:** do not clamp in the sealing area from the base.

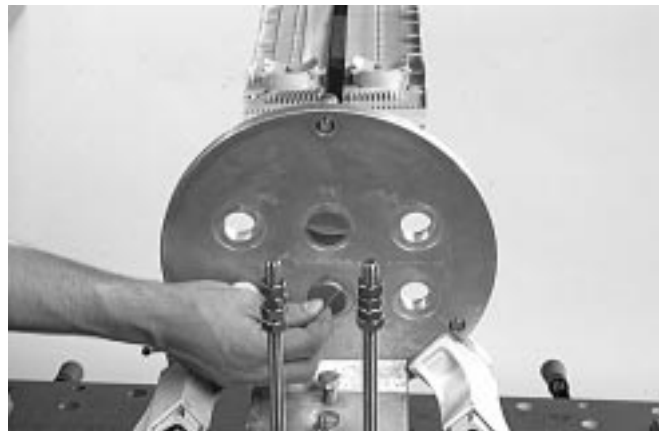

4.1.3 Remove the plastic plugs.

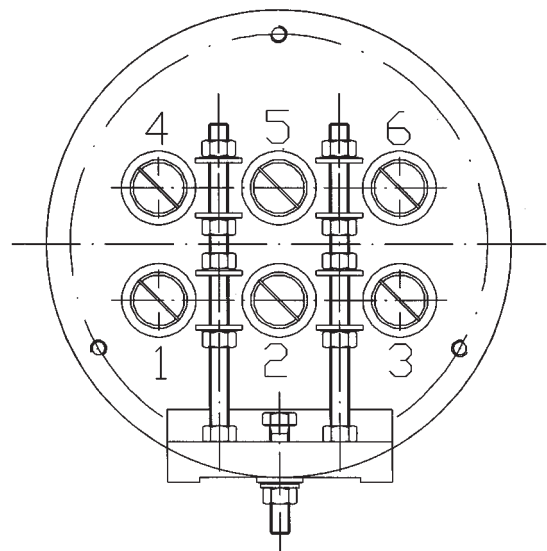

**Bottom of closure**

# of OPGW (inc./leav.)	Nr. of feedthrough for incoming OPGW	Nr. of feedthrough for Outgoing OPGW
2	1	3
4	1 4	3 6
6	1 4 2	3 6 5

4.1.4 Determine the cable position and install the cable feedthrough.

- Note:**
- Start at the bottom row (port n° 1, 2, 3).
  - If OPGW or plastic sheathed FO cable with  $\leq 12$  fibers per tube is installed, use ports n° 2 and 5. In this case the fibers will go directly to the SECO (see point 9.3 or 10.4).



4.1.5 Install metal caps (PG 21) into unused ports. Remove protection cap from metal cap (PG 21). Apply silicone grease (included in kit) on the sealing ring and apply Molykote grease (included in kit) on the thread of the metal cap (PG21) before installing.  
**Important:** this grease is very important to be able to access the ports at a later date.



4.1.6 Install the metal caps with O-ring and tighten them.



4.1.7 Install the glands and/or reductions on the cable feed-through (included in kit when necessary).  
 Note: when several reductions and glands are included in the kit, choose the appropriate items corresponding with the cable diameter. See flyer included in kit.  
**Important:** apply Molykote grease on the threads.



4.1.8 Install the cable feed-through with O-ring and tighten them.  
**Important:** apply silicone grease on the sealing ring and apply Molykote grease on the thread of the cable feed-through before installing.

## 4.2 Installation of cable clamps

4.2.1 Take the cable clamps (delivered with closure).



4.2.2 Install the clamp. Start at the bottom row (port no 1, 2, 3) and centre it with the ports entry's.

## 5 Installation of optical grounding wires (OPGW)

### 5.1 OPGW preparation

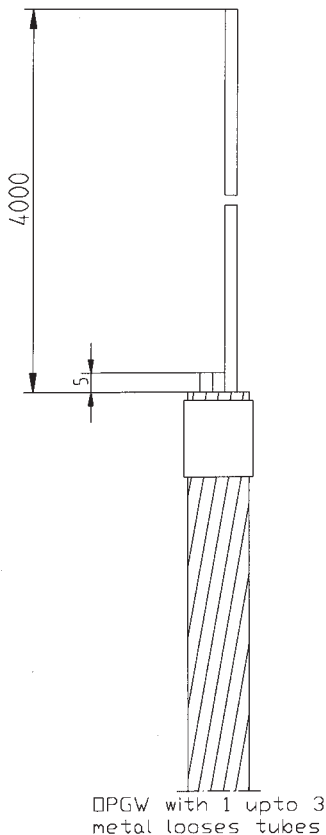

5.1.1 Straighten the cable over a minimum length of 4 m.

5.1.2 Mark the cable at 4 m and wrap tape around the cable at the marking point.

5.1.3 Make a circumferential incision in the cable at the marking point by using a saw or file.

5.1.4 Remove the aluminium cable strands starting from the cable end.

5.1.5 Break the strands and remove the sharp edges with a file.

5.1.6 Separate the metal loose tubes from the steel strands.

5.1.7 Remove the central steel strands according to above drawing.

5.1.8 Remove sharp edges with a file.

**Attention:** put a metal plate between metal loose tubes and steel strands during removal. Check metal loose tubes for damage after removal of steel strands and filing.

### 5.2 Installation of OPGW cable

Inserting the OPGW cable through the feedthrough into the closure

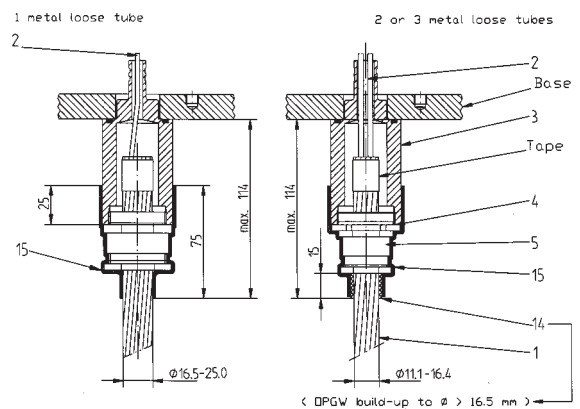

5.2.1 Slide the necessary heat-shrink tubes over the cables.

5.2.2 MWTM-50/16 (in feed-through and sealing kit), to be installed over the cable feed-through, reduction and gland onto the OPGW cable (needed on all inserted cables) (n° 15 on drawing).

5.2.3 When cable diameter is smaller than 16.5 mm, cut a MWTM-25/8 to a length of 15 mm to built up the OPGW cable between the cable clamps and the cable feed-through (n° 14 on drawing 5.2.1).



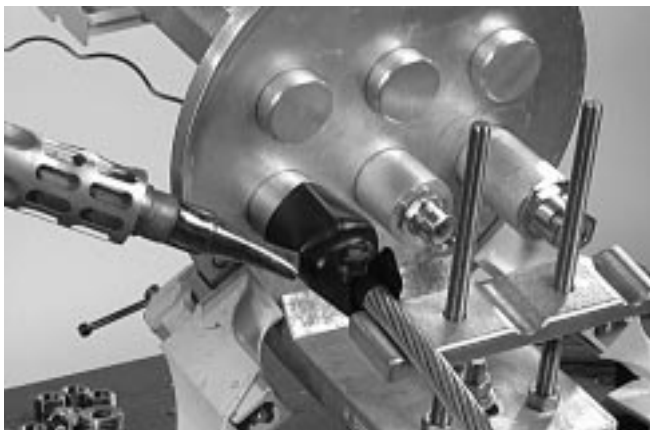
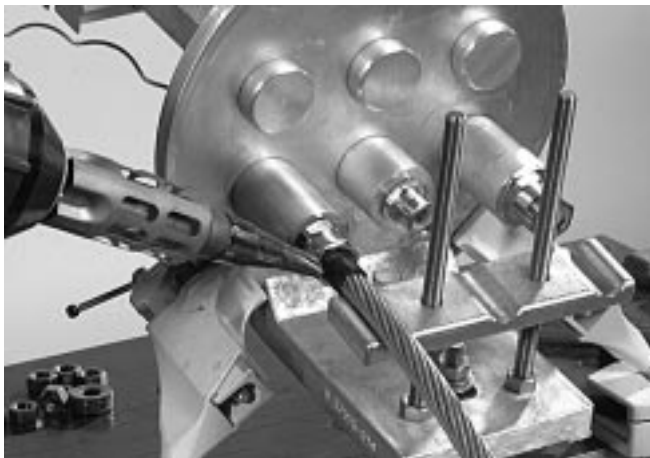
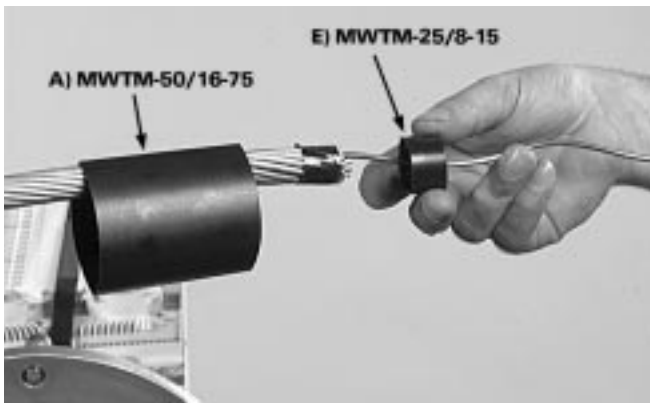

5.2.4 Slide necessary tubes over cable. Push the OPGW cable through the cable feed-through and tighten the gland. Check by pulling on the cable if the gland is tightened properly. Install the necessary heat-shrink tubes.

**Attention:** MWTM should NOT be in-between the cable clamps after installation (equipotential).

Build-up OPGW/FO cables in-between the cable clamps with Al-tape or Tubing(MWTM)

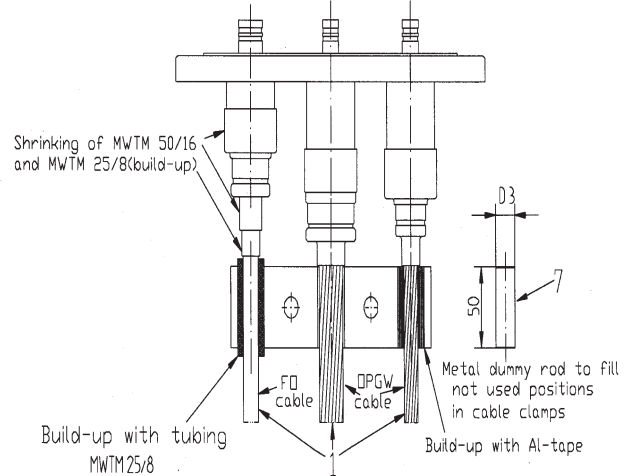

5.2.5 When necessary use Aluminum tape to built up the cable diameter of an OPGW cable in-between the cable clamps so it has the same diameter as the adjacent cable (OPGW or FO cable) (see drawing).

## 6 Installation of plastic sheeted FO cable

### 6.1 Preparation

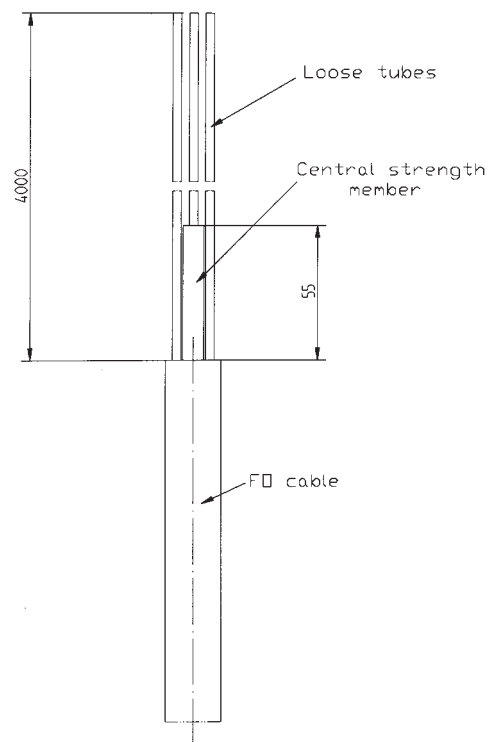

6.1.1 Remove the cable jacket at 4 m and clean the loose tubes.

6.1.2 Cut the strength member at 55 mm from the cable jacket.

## 6.2 Installation

Inserting the FO cable through the feedthrough into the closure

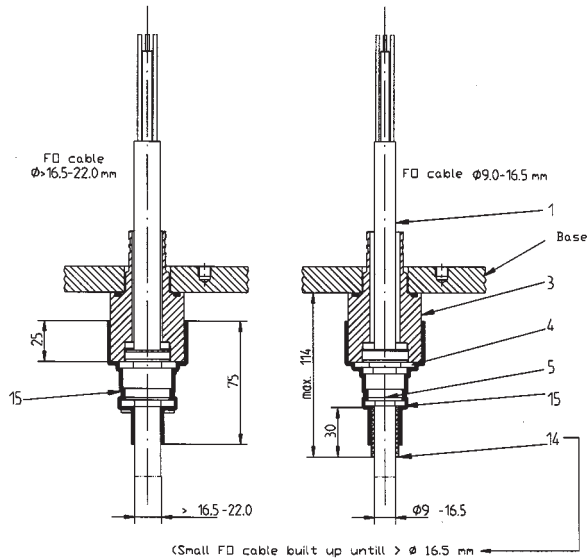

6.2.1 Slide the necessary heat-shrink tubes over the cables.

6.2.2 MWTM-50/16 (in feed-through & sealing kit), installed over the cable feed-through, reduction and gland onto the FO cable (needed on all inserted cables) (n° 15 on drawing).

6.2.3 When cable diameter is smaller than 16.5 mm, cut a MWTM-25/8 to a length of 30 mm to built up the FO cable between the cable clamps and the cable feed-through (n° 14 on drawing point 6.2.1).



6.2.5 When built up is required, feed the cable through the feed-through (inside 45 mm above feed-through, see drawing 10.1). Mark the cable at the cable clamp and at end of gland then pull the cable back.

Build-up □PGW/FO cables inbetween the cable clamps with Al-tape or Tubing(MWTM)

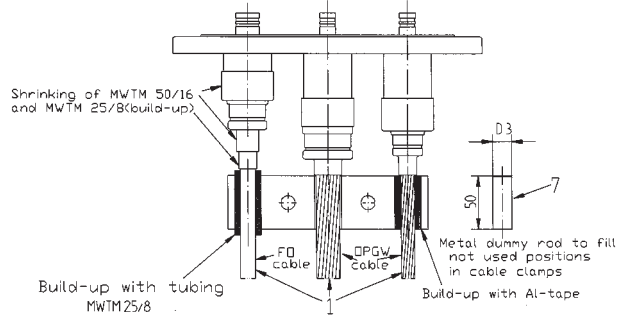

6.2.4 When necessary cut a MWTM-25/8 to a length of 50 mm to built up the cable diameter of a FO cable between the cable clamps so it has the same diameter as the adjacent cable (OPGW or FO cable) (see drawing).





6.2.6 Slide necessary tubing over cable and install appropriate tubing at the marks.

**Note:** Make sure the cable is cleaned before installing tubes.



6.2.7 Feed cable back through feed-through in position and tighten gland. Check by pulling on the cable if the gland is tightened properly. Install MWTM-50/16-75.

## 7 Installation of Optical Grounding Wires (OPGW) with inner cable jacket and plastic loose tubes

### 7.1 Preparation

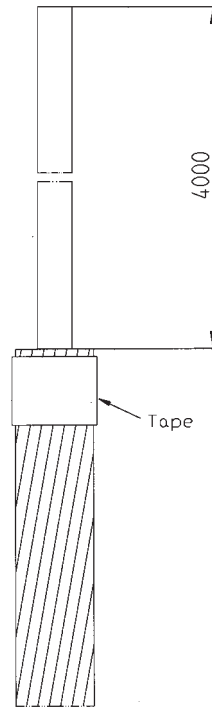

□ OPGW with inner jacket and plastic loose tubes.

7.1.1 Straighten the cable over a minimum length of 4 m.

7.1.2 Mark the cable at 4 m and wrap tape around the cable at the marking point.

7.1.3 Make a circumferential incision in the cable at the marking point by using a saw or file.

7.1.4 Remove the aluminium cable strands starting from the cable end.

7.1.5 Break the strands and remove the sharp edges with a file.  
**Note:** check inner cable jacket for damage and clean it after filing.

## 7.2 Installation

Inserting the OPGW with inner jacket and plastic loose tubes through the feedthrough into the closure

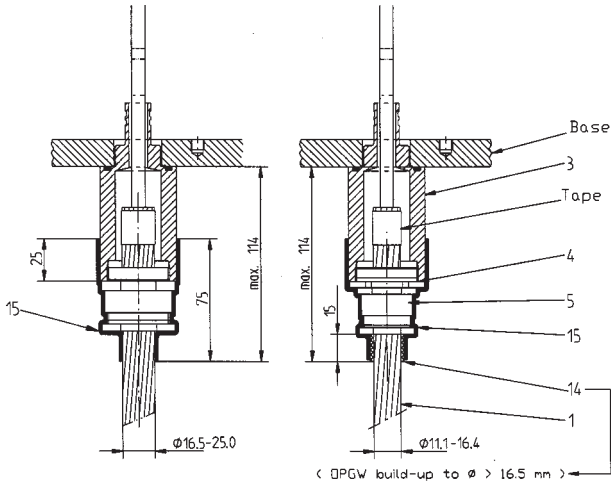

7.2.1 Slide the necessary heat-shrink tubes over the cables.

7.2.2 MWTM-50/16 (in feed-through and sealing kit), installed over the cable feed-through, reduction and gland onto the OPGW cable (needed on all inserted cables ) (n° 15 on drawing)

7.2.3 When cable diameter is smaller than 16.5 mm, cut a MWTM-25/8 to a length of 15 mm to built up the OPGW cable between the cable clamps and the cable feed-through (n° 14 on drawing point 7.2.1).

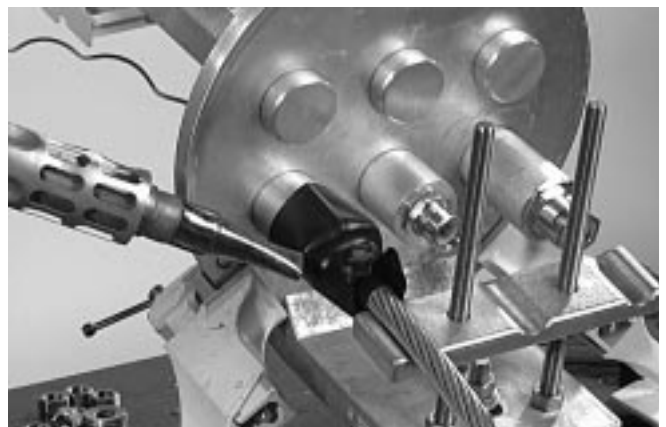
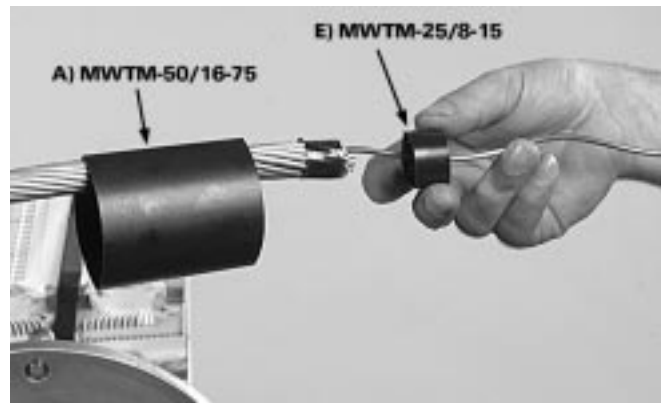

7.2.4 Slide necessary tubes over cable. Push the OPGW cable through the cable feed-through and tighten gland. Check by pulling on the cable if the gland is tightened properly. Install the heat-shrink tubes. **Attention:** MWTM should NOT be in-between the clamps after installation (equipotential).

Build-up OPGW/FO cables inbetween the cable clamps with Al-tape or Tubing(MWTM)

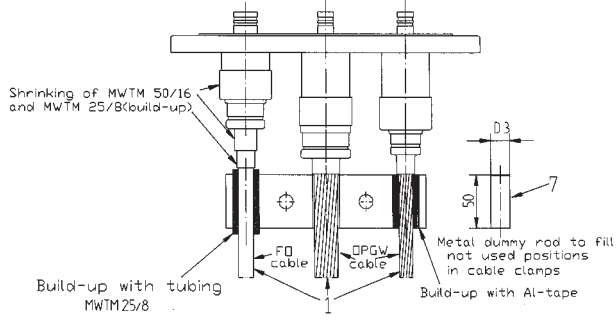

7.2.6 When necessary use luminum tape to built up the cable diameter of a OPGW cable between the cable clamps so it has the same diameter as the adjacent cable (OPGW or FO cable ) (see drawing).

## 8 Closing cable clamps



8.1 Install second half of cable clamp, centre the cable clamps and tighten:

8.2 When there are cables inserted in top row (ports 4, 5, 6) repeat steps from section 4.

## 9 Termination, sealing and routing of OPGW cable with $\leq 12$ fibers/metal tube

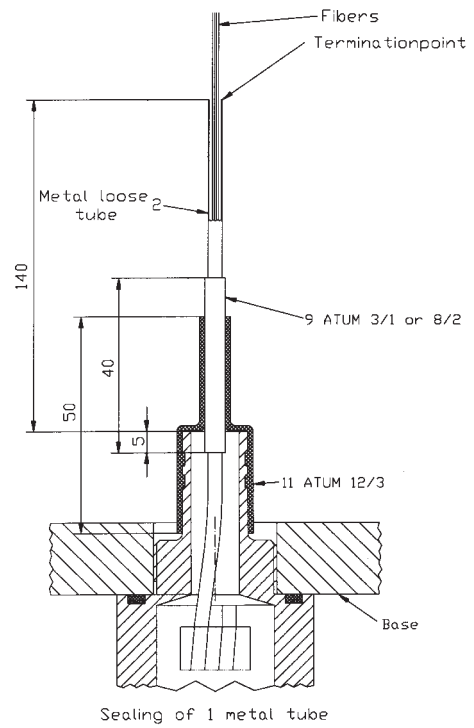

Sealing of 1 metal tube

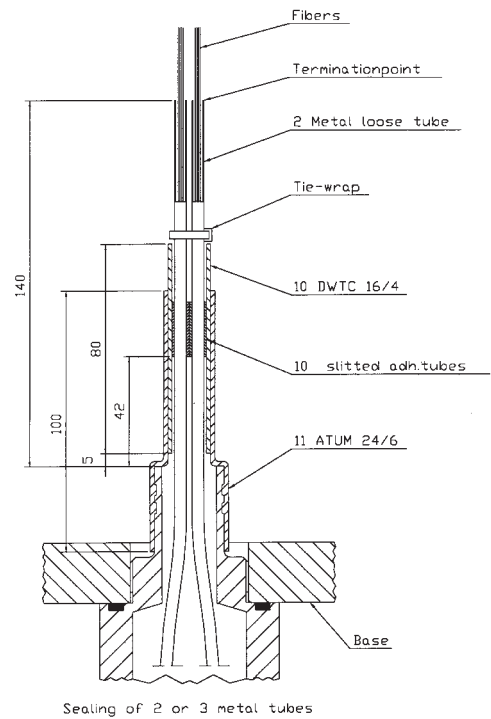

Sealing of 2 or 3 metal tubes

9.1 Strip the metal loose tubes according to the drawing .

9.2 Install applicable seals(in feed-through and sealing kit) according to drawing.

**Note:** Straighten the metal tubes before beginning to install the seal.

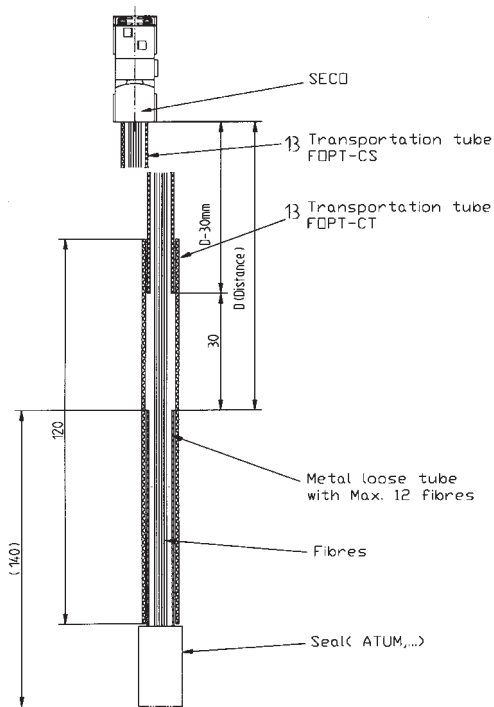

9.3 Determine the length (D) of the protection tube FOPT-CS between the end of the metal loose tube and the SECO. Cut the FOPT-CS 30 mm shorter.

9.4 Cut and install the FOPT-CT according to the drawing.

## 10 Termination, sealing and routing of plastic sheathed FO cable or OPGW with inner cable jacket and plastic loose tubes with $\leq 12$ fibers/plastic loose tube

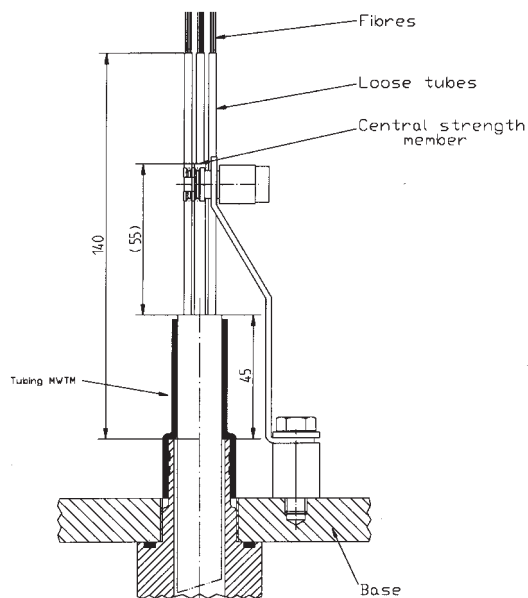

10.1 Install the strength member bracket according to the drawing.

10.2 Strip the loose tubes according to drawing.

10.3 Seal the cable jacket according to drawing.

10.4 Install the central strength member attachment according to drawing. In case of the OPGW cable with inner cable jacket, the construction can be a slotted core with plastic loose tubes. The aluminium slotted core is then filled until it fits in the strength-member attachment. In case inner jacket is not sealed, use blocking kit FOSS-MCO-CABBLOCK to seal.

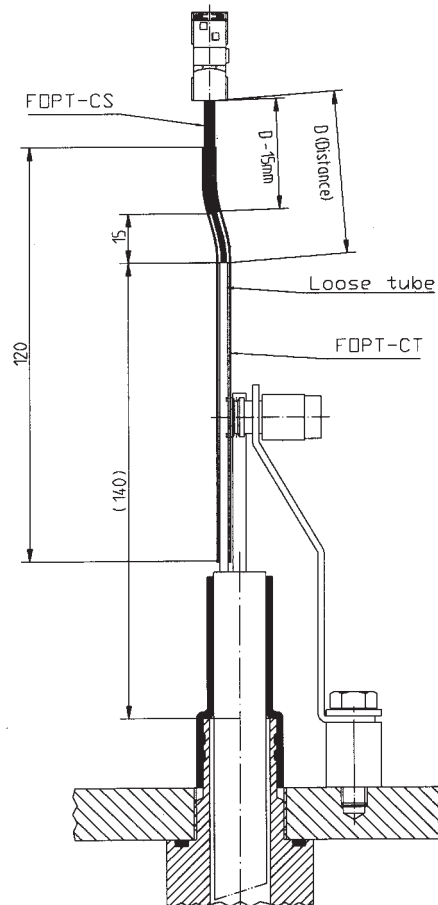

10.5 Determine the length (D) of the protection tube FOPT-CS between the end of the plastic loose tube and the SECO. Cut the FOPT-CS 15 mm shorter (see drawing).

10.6 Cut and install the protection tube FOPT-CT according to the drawing.

# 11 Termination, sealing and routing of OPGW cable or OPGW cable with $\geq 12$ fibers/metal loose tube

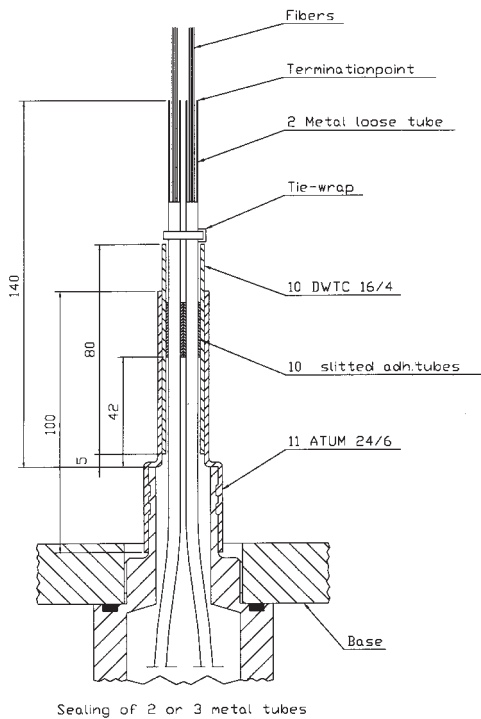
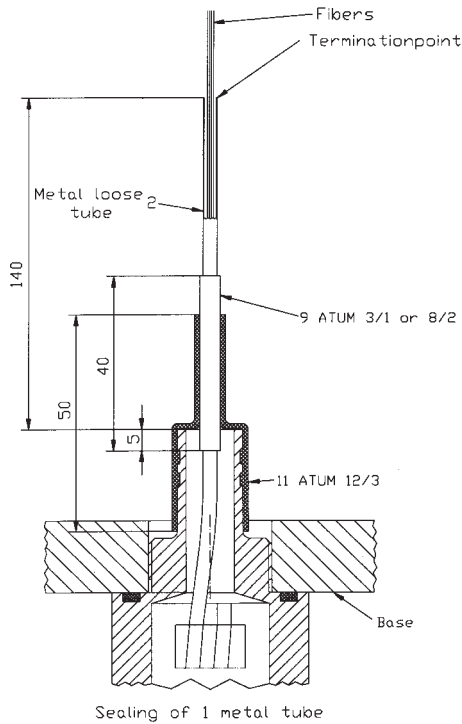

- 11.1 Strip the metal loose tubes according to the drawing.
- 11.2 Install applicable seals (in feed-through and sealing kit) according to drawing.

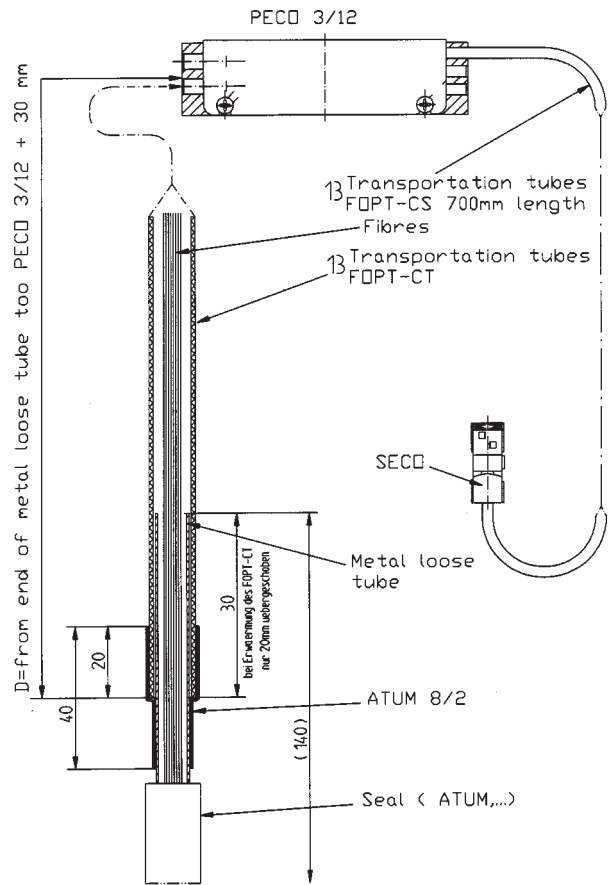

- 11.3 Determine the length (D) of the protection tube FOPT-CT between the end of the metal loose tube and the PECO 3/12 (positioned between the FAS plates, see p.11.13). Cut the FOPT-CT to a length of D plus 30 mm (see drawing).
- 11.4 Cut the other protection tubes according to drawing, install them and the heat shrink seals.
- 11.5 Shrink the seal over the protection tube FOPT-CT and the metal loose tube according to drawing.  
**Attention:** if the metal loose tube  $> 3.1$  mm the FOPT-CT needs to be expanded.
- 11.6 Remove the PECO 3/12 cover.



- 11.7 Feed the fibers in the PECO 3/12 entry's 1, 2 or 3. Push the FOPT-CT in the entries.



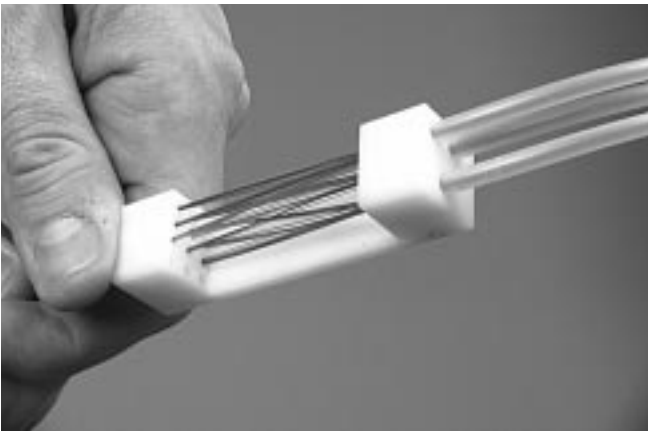

11.8 Break out the fibers (max. 12 per outlet) and feed them in the PECO 3/12 outlets 1-12.

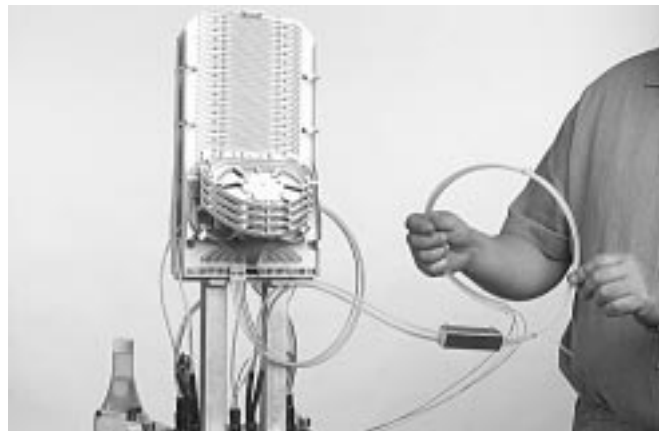

11.12 Bring the FOPT protection tubes together with tie wraps.

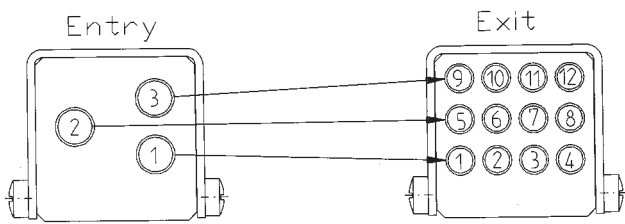

11.9 PECO 3/12 lay-out.



11.10 Cut the FOPT-CS to a length of 700 mm. feed the fibers through and push the FOPT-CS in the PECO 3/12 outlets. Pull gently on the fibers.



11.13 Position the PECO 3/12 between the two FAS plates. Be careful not to kink the FOPT protection tubes.



11.11 Put the PECO 3/12 cover back.



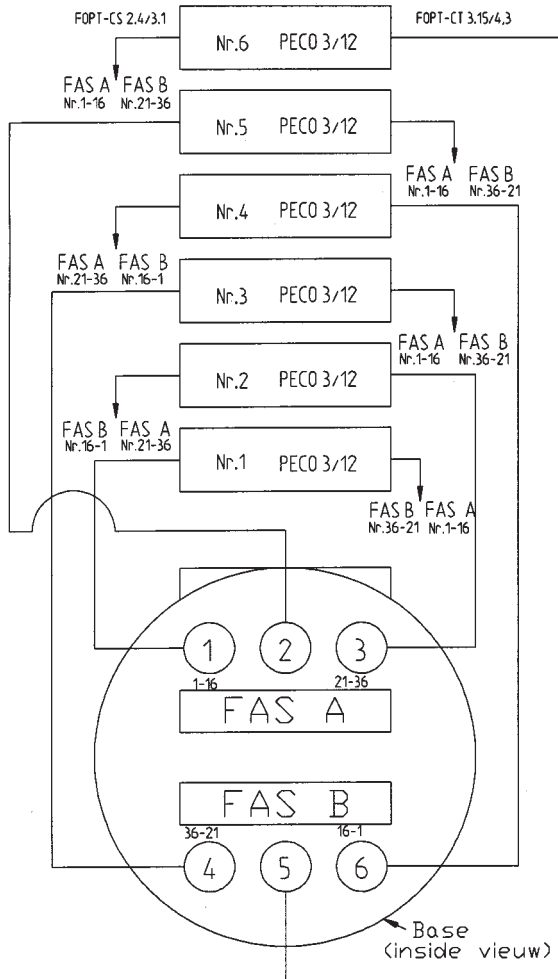

11.14 Determine the positions of the SECOs (see drawing).

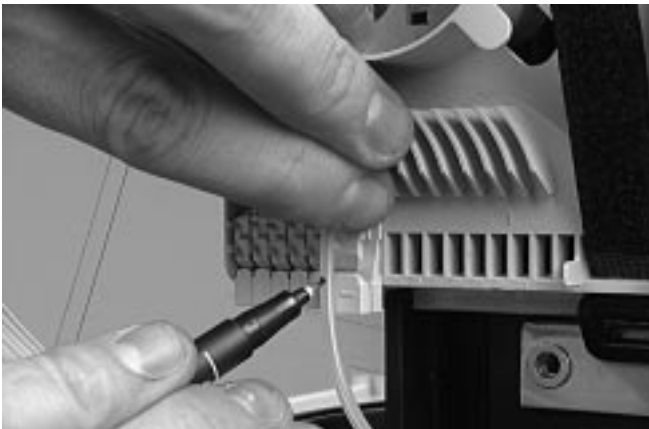

11.15 Rout the FOPT-CS protection tubes to the SECOs and mark them.

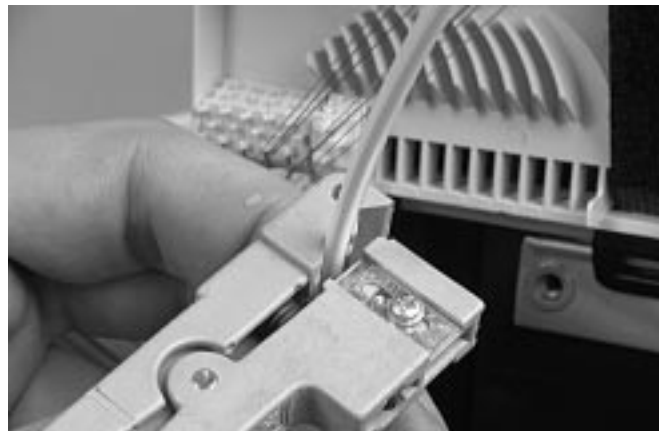

11.16 Carefully cut and remove the FOPT-CS protection tube at this marking point.

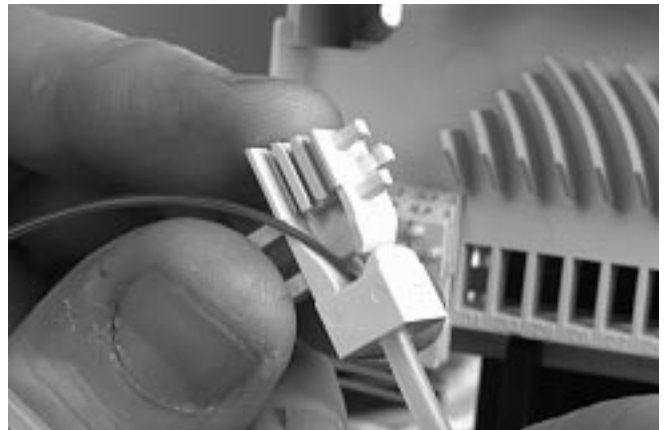

11.17 Install the FOPT-CS protection tube in the SECO.



11.18 Bring together the FOPT-CS protection tubes with tie wraps on the FAS plate eyelet.

## 12 Placing SOSA and/or SASA and routing fibers

See SOSA/SASA installation instruction.

## 13 Closing the closure

13.1 Apply silicone grease on the sealing ring and place it back on the base.

13.2 Place a new bag of silica gel on the base.

13.3 Place the dome and tighten the bolts.

13.4 Bring the closure to its position and attach it.

## 14 Mounting the closure without drilling holes



14.1 The MCO-MOBRA-1 is designed to mount the closure without drilling onto L-shape profiles of the pole.



14.2 Attach the MOBRA onto the closure with the 2 screws.



14.3 Attach the MOBRA and closure to the L-shape profiles of the pole with the two C-clamps.

### Tyco Electronics Raychem NV

#### Telecom Outside Plant

Diestsesteenweg 692  
B-3010 Kessel-Lo, Belgium  
Tel.: 32-16-351 011  
Fax: 32-16-351 697  
www.tycoelectronics.com

The information given herein, including drawings, illustrations and schematics which are intended for illustration purposes only, is believed to be reliable. However, Tyco Electronics makes no warranties as to its accuracy or completeness and disclaims any liability in connection with its use. Tyco Electronics' obligations shall only be as set forth in Tyco Electronics' Standard Terms and Conditions of Sale for this product and in no case will Tyco Electronics be liable for any incidental, indirect or consequential damages arising out of the sale, resale, use or misuse of the product. Users of Tyco Electronics products should make their own evaluation to determine the suitability of each such product for the specific application.